

# DIRECT BURIED MICRO-DUCT CONNECTORS

Product Technical sheet

PATENTED

## ABOUT

Plas-fit Direct Buried connectors are used for the connection of micro-ducts for fiber-optic cables in the telecommunications industry with the following characteristics:

- Comply to European Regulation (EC) No. 1907/2006 (REACH) Annex XVII and its amendment (EU) 2018/2005.
- Comply to Directive 2011/65/EU of the European parliament and of the Council of June 2011, on the restriction of the use of certain Hazardous Substances in electrical and electronic equipment. (RoHS II)
- Designed for Direct Buried installation in harsh environments without need for any protective sheathing.
- Can be dismantled for re-use.
- Fast and easy installation without need for any tooling for assembly or removal.
- The connectors are resistant to pressures used in the industry for blowing cables through guide tubes (micro-ducts) and provide protection from dirt and water.
- The connectors are of a push-fit design for quick and easy installation and disassembly \*.
- The connectors has transparent body for easy and secure installation and to verify that the Micro- duct reaches the required position
- Minimal interference to cable passage to due unique design of the internal structure of the connector.
- The connectors comply with the relevant sections of EN 50411-2-8:2009 as described in the technical specification section.

## AVAILABLE PRODUCTS

Cat No	Size (mm)	Description
40006M3006	6x6	Direct Buried Connector
40007M3007	7x7	Direct Buried Connector
40008M3008	8x8	Direct Buried Connector
40010M3010	10x10	Direct Buried Connector
40012M3012	12x12	Direct Buried Connector
40014M3014	14x14	Direct Buried Connector
40016M3016	16x16	Direct Buried Connector
40018M3018	18x18	Direct Buried Connector
40020M3020	20x20	Direct Buried Connector



Cat No	Size (mm)	Description
40006S3000	6	Direct Buried End-Stop
40007S3000	7	Direct Buried End-Stop
40008S3000	8	Direct Buried End-Stop
40010S3000	10	Direct Buried End-Stop
40012S3000	12	Direct Buried End-Stop
40014S3000	14	Direct Buried End-Stop
40016S3000	16	Direct Buried End-Stop
40020S3000	20	Direct Buried End-Stop



Cat No	Size (mm)	Description
40010D3007	10x7	Direct Buried Reducer
40010D3008	10x8	Direct Buried Reducer
40012D3007	12x7	Direct Buried Reducer
40012D3008	12x8	Direct Buried Reducer
40012D3010	12x10	Direct Buried Reducer
40014D3010	14x10	Direct Buried Reducer
40014D3012	14x12	Direct Buried Reducer
40016D3012	16x12	Direct Buried Reducer
40016D3014	16x14	Direct Buried Reducer



\* NOTE: if pipe and connectors has been under pressure, the grip-ring needs to be changed by recycling before re-using for other pipe.

## MATERIALS

The following data is relevant for Straight-Connectors, End-Stops and Reducing connectors:

#	Part	Raw Material	color
1	BODY	Polypropylene	Transparent
2	WASHER	Polypropylene	Transparent
3	NUT	Polypropylene	Blue
4	GRIP RING	Aromatic PA PPA	Depending on the size
5	O- RING	EPDM	Black

- All parts are made of plastic with maximum endurance for water and chemicals, and wide range of storage, installation and usage temperatures and humidity.
- Seal and internal parts are protected from dirt by the internal structure of the connector.
- The use of 100% plastic durable materials and unique structure of the connector allows using it in Direct Buried installations without need for any additional protection.
- Patented grip ring.
- Life Time : >30 years in direct buried conditions.

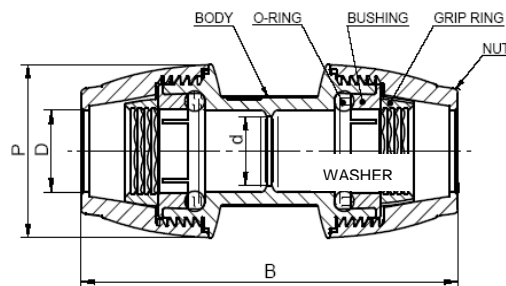

### Duct Allowed Dimensions

DN	d min	d max	Ovality
7	6.9	7.1	<5%
8	7.9	8.1	<5%
10	9.9	10.2	<5%
12	11.9	12.2	<5%
14	13.9	14.2	<5%
16	15.9	16.2	<5%
20	19.9	20.3	<5%

## TECHNICAL SPECIFICATIONS

### Temperatures

Minimum working temperature: - 15°C

Maximum working temperature: + 45°C

### Pressure

The connectors withstand successfully air pressure test according to the below testing protocol:

- The tested connector is connected between 2 standard ducts and put under a pressure of 15 bar for 30 min and afterwards sealed and disconnected from the compressor.
- The test is considered as successful if after a duration of 1 hour the pressure dropped less than 1,5 bar.
- After this test, the connector is removed without connector damage.

Detailed below for all temperatures in the working range:

- Continuous working pressure: 16bar
- Peak working pressure: 20bar

### Burst pressure

- The connectors withstand Burst Pressure Test (Safety) of at least 25 bar.
- Tested at -10degC and 40degC according to EN50411-2-8:2009 Annex. C

### Leak-tightness under external pressure

All connectors withstand 1.35 bar external water pressure.

### Insertion Force

The force necessary to insert a tube in the connector is < 5kg (50N)

(Tested according to EN50411-2-8:2009 Annex. E)



### Microduct Retention

The connectors resist pull out forces as required by EN 50411-2-8:2009 between the connector and the microduct as follows:

(All done in 100mm/min speed).

Test	Conditions	7mm	8mm	10mm	12mm	14mm	16mm	18mm	20mm
*Continuous pull-out:	(1h, 23°C)	>300N	>350N	>450N	>650N	>900N	>950N	>1000N	>1000N
Violent pull-out: (jerk)	(< 0.3 sec, 23°C)	>800N	>850N	>950N	>1200N	>1500N	>1800N	>2000N	>2000N

\* Note (1): Results on micro-ducts manufactured from PE100 material. The quality of the duct material will affect the pull -out test results due to "necking".

\*\* Note (2) : if pipe and connectors has been under pressure, the grip-ring needs to be changed by recycling before re-using for other pipe.

### Impact

The connectors withstand impact force as required by EN 50411-2-8:2009, according to the following procedure:

- Connect 2 ducts using a straight connector and end-stop at one end.
- Bring the set to required temperature (done in (-15degC) and (+45degC) for 4 hours.
- Drop a weight of 1.0kg with radius 12.5mm on the center of the fitting from relevant height (1 Joule)
- Perform pressure test (0.4 Bar for 15 Minutes) – Passed.

NOTE: An advanced version of Hi-Impact Plas-Fit DB connectors is available. The Hi-Impact connectors resist impact force of 15 Jauls at temperature range of (-10 DegC) to (+45DegC).

## DIMENSIONS

### Straight Connector

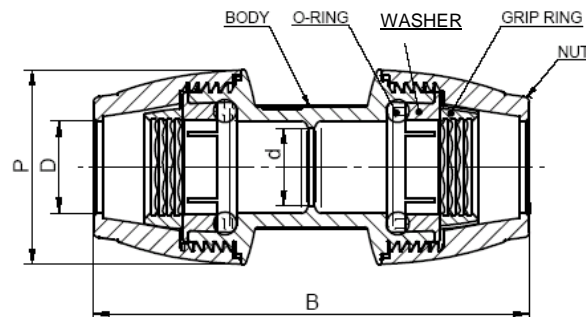

Part no.	DN	D	d	P	B
40007M3007	7	7.4	6.0	19.0	48.0
40008M3008	8	8.3	7.0	20.4	53.0
40010M3010	10	10.4	8.5	24.0	58.0
40012M3012	12	12.4	10.0	26.0	61.8
40014M3014	14	14.3	12.0	30.0	67.0
40016M3016	16	16.4	14.0	33.5	72.0
40020M3020	20	20.4	18.0	37.5	87.0

### End Stop

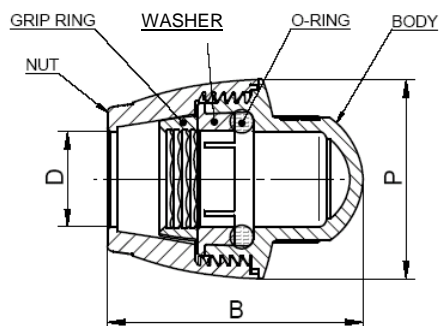

Part no.	DN	D	P	B
40007S3000	7	7.4	19.0	27.7
40008S3000	8	8.3	20.4	29.9
40010S3000	10	10.4	35.0	35.0
40012S3000	12	12.4	26.0	37.4
40014S3000	14	14.3	30.0	38.0
40016S3000	16	16.4	33.5	42.2
40020S3000	20	20.4	37.5	51.0